



Schottky Barrier Diode

BAT54H

FEATURES

- Low Forward voltage — 0.35Volts(Typ.).
@ $I_F=10\text{mA}$
- Extremely fast switching speed
- Ultra-small surface mount package
- PN junction guard ring for transient and ESD protection



Lead-free

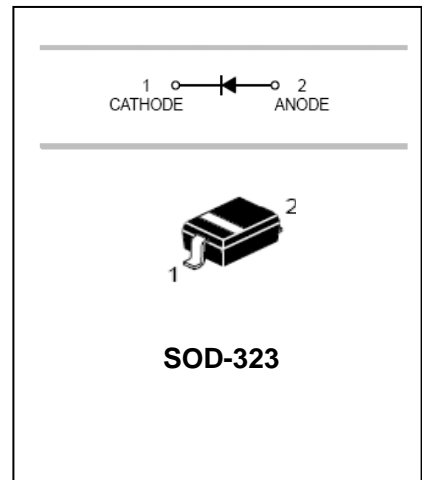

APPLICATIONS

- Schottky barrier detector and switching diodes

ORDERING INFORMATION

Type No.	Marking	Package Code
BAT54H	JV	SOD-323

MAXIMUM RATING @ $T_a=25^\circ\text{C}$ unless otherwise specified

Parameter	Symbol	Limits	Unit
DC reverse voltage	V_R	30	V
Forward continuous Current	I_F	200	mA
Repetitive peak Forward Current	I_{FRM}	300	mA
Forward Surge Current @ $t<1.0\text{s}$	I_{FSM}	600	mA
Power Dissipation	P_d	200	mW
Thermal resistance, junction to ambient air	$R_{\theta JA}$	635	$^\circ\text{C}/\text{W}$
Junction temperature	T_j	150	$^\circ\text{C}$
Storage temperature range	T_{stg}	-55 to +150	$^\circ\text{C}$



Schottky Barrier Diode

BAT54H

ELECTRICAL CHARACTERISTICS @ Ta=25°C unless otherwise specified

Parameter	Symbol	Conditions	Min.	Typ.	Max.	Unit
Reverse Breakdown Voltage	$V_{(BR)R}$	$I_R=10\mu A$	30			V
Forward voltage	V_F	$I_F=0.1mA$		0.22	0.24	V
		$I_F=1.0mA$		0.29	0.32	V
		$I_F=10mA$		0.35	0.40	V
		$I_F=30mA$		0.41	0.5	V
		$I_F=100mA$		0.52	0.8	V
Reverse leakage current	I_R	$V_R=25V$		0.5	2.0	μA
Reverse recovery time	t_{rr}	$I_F=10mA, I_R=1.0mA$			5.0	ns
Total capacitance	C_T	$V_R=1.0V, f=1.0MHz$		7.6	10	pF

TYPICAL CHARACTERISTICS @ Ta=25°C unless otherwise specified

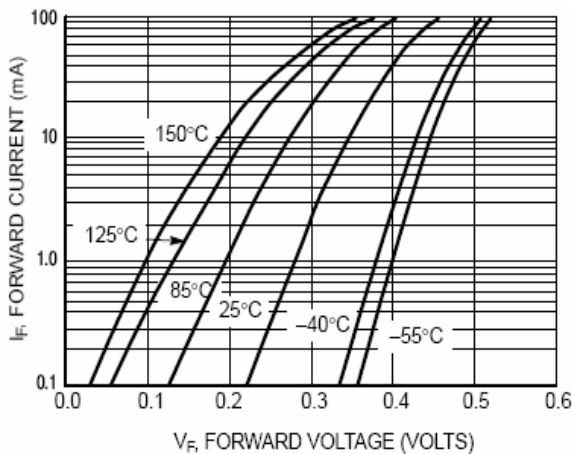

Figure 1. Forward Voltage

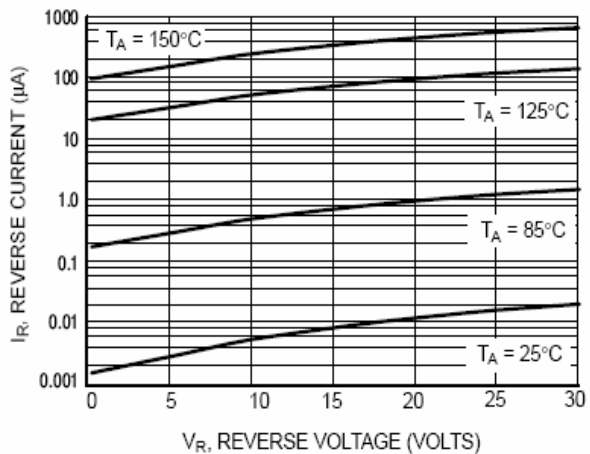

Figure 2. Leakage Current

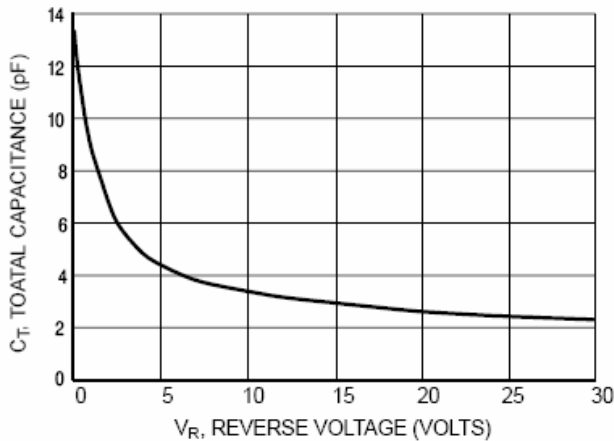

Figure 3. Total Capacitance

Schottky Barrier Diode

BAT54H

PACKAGE OUTLINE

Plastic surface mounted package

SOD-323

SOD-323		
Dim	Min	Max
A	1.275	1.325
B	1.675	1.725
C	0.9 Typical	
D	0.30 Typical	
E	0.27	0.37
H	0.02	0.1
J	0.1 Typical	
K	2.6	2.7
All Dimensions in mm		

SOLDERING FOOTPRINT

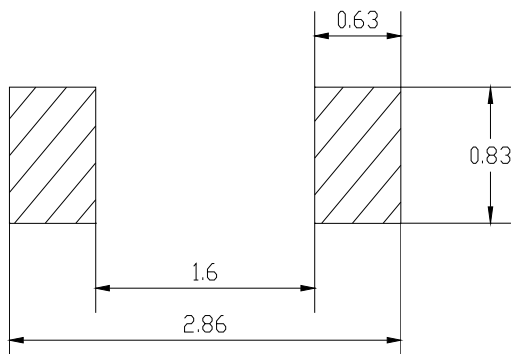

Unit : mm

PACKAGE INFORMATION

Device	Package	Shipping
BAT54H	SOD-323	3000/Tape&Reel